

City of Thornton, Colorado
**Small Cell Design
Guidelines**



HRGreen

5619 DTC Parkway, Suite 1150
Greenwood Village, CO 80111
720-602-4999
Learn more at HRGreen.com

PREPARED FOR



9500 Civic Center Drive
Thornton, CO 80229

February 15, 2022

Table of Contents

1. Executive Summary	4
1.1 Background	4
1.2 Small Cell Facility Aesthetic Standards	4
2. General Information	5
2.1 Definitions	5
2.2 Application Requirements	9
2.2.1 Application Submittal and Review	9
2.2.2 Application Requirements	9
2.2.3 Application Approval Timeline and Shot Clock	10
2.2.4 Expiration of Approval	11
2.2.5 Specific Exclusions	11
2.3 Fees	11
3. Pole Design Standards	13
3.1 Utility Distribution Poles	13
3.2 Streetlight Poles	13
3.2.1 Xcel Energy and United Power Streetlight Poles	14
3.2.2 City-Owned Streetlight Poles	15
3.3 Municipal Traffic Signal Poles	17
3.4 Applicant-Owned Poles	19
4. Pole Location, Height, and Sign Standards	21
4.1 Location	21
4.1.1 Permitted Locations	21
4.1.2 Excluded Locations	21
4.1.3 Historical Districts, Parks, and Open Space	22
4.2 Height	22
4.3 Signs	22
5. Safety Requirements and Noise	23
Appendix A: Designs	24
A.1 Diagram of Small Cell Facility Pole	24
A.2 Base Cabinet	25
A.3 Upper Antenna Module	27
A.4 Foundation Selection	28

A.5 Lighting Accessories29

1. Executive Summary

1.1 Background

The State House Bill 17-1193, and Federal Communications Commission’s (“FCC”) Declaratory Ruling and Third Report and Order, *Accelerating Wireless Broadband Deployment by Removing Barriers to Infrastructure Investment* (the “Order”) enacted in early 2019 articulated the rights wireless providers have to the public rights of way to access, use and locate wireless infrastructure. The purpose of the FCC Order is streamline the rollout of wireless infrastructure. The FCC Order outlines the extent to which local governments may regulate the installation of wireless facilities on existing public infrastructure located within the public rights-of-way. The State law likewise proscribes that local governments must allow wireless providers access and use of the public right of way in the same manner as other permitted users and utilities.

However, both Federal and State regulatory laws recognize local governments like Thornton, reserve the authority to manage the use, installation and construction of wireless infrastructure based on public health, safety, and welfare, and if necessary deny or require wireless providers to modify their requested use when it conflicts with other permissible uses of the public right of way or are otherwise unlawful. Because the current provisions in the City of Thornton Code’s **Chapter 18 under Article 9, Wireless Telecommunication Facilities**, were adopted for large cell towers, however, the Code does not adequately address the unique issues small cell facilities will likely create. These Guidelines are intended to specifically address the access, management and regulation of small cell facilities located in Thornton’s public right of way. To the extent that other provisions of the City Code establish a parallel process for review and approval of a small cell facility, the provisions of this guideline shall control.

Wireless carrier providers have indicated that until recently, wireless, and broadband services generally have been managed using macro wireless (telecom) facility typically comprised of large cell antennas mounted on tall tower located on both public and private property. These macro towers serve relatively large areas or “cells” that provide coverage up to several miles away. However, these existing macro cell tower sites are already becoming congested and installing them in cities and urban areas would be contrary to current zoning regulations. On the other hand, small cell facilities are needed to keep up with the rapidly growing demand and need for high speed wireless data transmission. Similar to the advent of the telephone which required extensive wires, switch boxes, poles and other structures to provide these services, small cell facilities require structures and access in the public right of way. Likewise, small cell facilities may need to be as close as 400 to 500 feet apart to function.

To meet demands for wireless data, carriers have begun using these new lower-powered small cell facilities to “offload” data traffic from the larger cell towers. Each small cell facility will serve a much smaller area (1-2 blocks) but are capable of handling greater volumes of data. It is incumbent on Thornton to regulate small cell facilities to minimize aesthetic concerns such as appropriate siting in the public rights of way, interference with driver visibility, and their proliferation in and around public places, residential homes, businesses and other common areas.

These Guidelines will address federal, and state regulatory timeline or “shot clocks” for the approval of small cell facility applications, and Thornton’s small cell facility application requirements, and small cell requirements concerning, among other things, the permitting process, small cell facility aesthetic and design requirements, pole height limits, siting and location in the public rights of way, camouflage and concealment of a small cell facility, collocation on existing infrastructure, as well as safety and noise issues.

1.2 Small Cell Facility Aesthetic Standards

Aesthetic and design requirements must be reasonably objective and no more burdensome than those applied to other types of infrastructure deployments. Aesthetic standards must also be published in advance of the review to be enforceable.

2. General Information

2.1 Definitions

The definitions of City Code shall apply to this document unless defined differently here. If a word is not defined here or in City Code, it shall have the usual and customary meaning as defined in a standard dictionary. The following words, terms and phrases, when used in this article, shall have the meanings ascribed to them in this section, except where the context clearly indicates a different meaning:

Administrative Review means ministerial review of an Application by the City relating to the review and issuance of a Permit, including review by the designated staff to determine whether the issuance of a Permit is in conformity with the applicable provisions of these Guideline and all City Codes.

Antenna means the specific device used for the purpose of collecting or transmitting electromagnetic waves. Antennae include but are not limited to directional antennae (such as panels, microwave dishes, and satellite dishes) and omnidirectional antennae (such as whip antennae and vertical antennae).

Applicable Codes means any code drafted and adopted by the City as well as uniform building, fire, safety, electrical, plumbing, Uniform Traffic Control or mechanical codes adopted by a recognized national code organization to the extent such codes have been adopted or used by the City, including any amendments adopted by the City, or otherwise are applicable in the jurisdiction.

Applicable Laws means any and all current and future statutes, constitutions, charters, ordinances, resolutions, regulations, judicial decisions, rules, tariffs, franchises, administrative orders including but not limited to regulations and orders promulgated by the Federal Communications Commission, certificates, orders, or other requirements of the City, including specifically the ROW Ord., or other governmental or judicial authority having the force and effect of law that determines the legal standing of a matter.

Applicant means the person submitting an application that is proposing an action requiring review and approval by one or more of the sections in this chapter. An applicant may subsequently become the developer once approval is granted, and in this case the terms shall be interchangeable.

Applicant-Owned Pole means poles owned by the applicant or entity on behalf of which the applicant is acting either through construction of a new pole or the purchase of an existing Pole located in ROW or poles with respect to which the applicant or entity on behalf of which the applicant is acting otherwise controls or holds the rights to install, maintain, repair, relocate, and remove such poles and to allow attachments to such poles.

Application means the process by which a person submits a request to perform construction activity and/or indicates a desire to be granted permission in any way to utilize the rights-of-way of all, or a part, of the City. An application includes all written documentation, in whatever form or forum, made by a person to the City concerning: the installation of any type of public improvements, public utility facilities, the construction of a cable system or any type of information or telecommunications system over, under, on or through the rights-of-way.

Attached wireless facilities are those affixed to a structure except optical fiber, wires, coaxial cable and the mounting hardware used to attach optical fiber, wires, and coaxial cable. Examples of attached facilities include but are not limited to antennas, telephone boxes, power boxes, and other equipment boxes and cabinets on structures located on the ground.

Batched Application is the submission of multiple siting applications at one time. Batched applications shall not exceed 10 individual Small Cell Facilities.

City means the City of Thornton.

City cost means all costs borne by the City for the administration of this article.

City Council means the Thornton City Council.

City Manager means the Thornton City Manager or designee.

Code means the Thornton City Code.

Collocate means to install or mount a Small Wireless Facility in the Public ROW on an existing Support Structure, an existing Tower, or on an existing Pole to which a Small Wireless Facility is attached at the time of the Application. “Collocation” has a corresponding meaning.

Communications Facility means collectively, the equipment at a fixed location or locations within the Public ROW that enables Communications Services, including: (i) radio transceivers, Antennas, coaxial, fiber-optic or other cabling, power supply (including backup battery), and comparable equipment, regardless of technological configuration; and (ii) all other equipment associated with any of the foregoing. A Communications Facility does not include the Pole, Tower or Support Structure to which the equipment is attached.

Construction permit means the authorization to undertake any type of excavation or work, as defined herein, in the rights-of-way or to construct public improvements, as defined herein, in the City or undertake any construction activity within the City. A construction permit can be issued either as a ROW construction permit or as a site construction permit, as applicable.

Contractor means a person, partnership, corporation, or other legal entity who undertakes to construct, install, alter, move, remove, trim, demolish, repair, replace, excavate, or add to any improvements or public improvements covered by this article, that requires work to be undertaken and workers, and/or equipment to be in the ROW in the process of performing the above-named operations. Contractor, as the term is defined herein, should include any and all types of general contractor and subcontractor and successors or assigns of said contractor.

Development Code means Chapter 18 of the City Code, as amended.

Director means the Executive Director of the Infrastructure Department for the City.

Equipment Concealed Whenever technically feasible, antennas, cabling, and equipment shall be fully concealed within a Pole, or otherwise camouflaged to appear to be an integrated part of a Pole.

Excavate or excavation means to dig into, including boring into, or in any way remove, distribute or penetrate any part of a ROW.

Facilities means any and all equipment, structures, materials or tangible components located in the rights-of-way and used to provide a service, including without limitation: all plants, whether inside or outside, fiber strands or optic lines, electronic equipment, amplification equipment, optic equipment, transmission and distribution structures, antennas of any type, lines, termination equipment, pipes, poles, ducts, mains, conduits, inner ducts, regenerators, repeaters, underground lines, vaults, manholes, pull boxes, splice closures, wires and cables, and all other like equipment, fixtures and appurtenances used in connection with transmitting, receiving, distributing, offering, and/or providing such service. Facilities shall include, as the context dictates, wireless telecommunication facilities, as defined herein.

Franchise means a right granted by the City for use of the rights-of-way, or any other City-owned or City-controlled real property designated to be or actually used by public utilities, cable providers, or other operators/entities for which a franchise can be granted pursuant to law, for the construction, operation and/or maintenance of a public utility, or any type of cable system or other operations within all of the City or such portions therefore as may be proposed and authorized for such construction operation and/or maintenance, including the City's growth area. Any such authorization, in whatever form granted, shall not mean and shall not include any license or permit required for the privilege of transacting and carrying on a business within the City as required by this Code, other ordinances, resolutions or regulations of the City.

Height means maximum height of the small cell facility, including antenna, above established grade measured at the base of the structure

Inspector means the person designated by the City within the infrastructure department or the City development department to fulfill the responsibilities that have been empowered with such position.

Landscape means any combination of living plant material, such as trees, shrubs, vines, ground covers, flowers, vegetables, turf or grass; natural features, such as land and water forms; and structural features, including but not limited to landscaped pedestrian plazas, fountains, reflecting pools, screening, walls, fences and benches.

Macro Wireless Telecom Facility means telecommunication towers, poles or similar structures greater than 50 feet in height, including accessory equipment such as transmitters, repeaters, microwave dishes, horns, and other types of equipment for the transmission or receipt of such signals, as well as support structures, equipment buildings and parking areas.

Micro Wireless Facility means a small wireless facility, including a strand-mounted facility, that is no larger in dimensions than twenty-four inches in length, fifteen inches in width, and twelve inches in height and that has an exterior antenna, if any, that is no more than eleven inches in length.

Monopole means a standing antenna support structure with no guy wires placed directly on the ground to support one or more small cell facilities.

Multi-User Facility means a facility that is designed to accommodate two or more service providers.

Ordinary Maintenance and Repair means inspections, testing and/or repair that maintain functional capacity, aesthetic and structural integrity of a Communications Facility and/or the associated Support Structure, Pole or Tower, that does not require blocking, damaging or disturbing any portion of the Public ROW.

Permittee means any person making application for or in possession of any type of construction permit to perform any construction activity, excavation, or work within the corporate limits of the City.

Provider means any person including a franchisee who is providing or is in the process of seeking permission to provide a service to citizens of the City through the placement of facilities or structures either owned or leased in and thereby occupying the rights-of-way, as defined herein.

Public improvements means any item placed or constructed in public rights-of-way intended for public use including, but not limited to: roadways, streets, alleys, sidewalks, curbs, gutters, trails, crosswalk or other traffic markings or traffic structures, utilities (water, sanitary sewer, or storm sewer) either owned by or dedicated to the City, or over which the City has or there is recorded a public easement, any private access either owned or dedicated to the City, parking lots, or landscaping, whether privately or publicly owned or maintained, unless otherwise specifically exempted within this chapter.

Responsible party means any person or entity who owns facilities or structures located or to be located in the City rights-of-way and/or who is liable, whether financially or otherwise, for any installation, repair, or maintenance of facilities, or public improvements, either public or private, placed on or to be placed in the City rights-of-way.

Rights of way or ROW means the surface and space above and below any real property in which the City has a real property interest and/or which have been dedicated to the public or is hereafter dedicated to the public and maintained under public City or by others at the direction of the public City and located within the City including, but not limited to, public: streets, roadways, highways, avenues, lanes, alleys, bridges, sidewalks, easements, public ways and similar public property and areas.

Sidewalk means a paved walkway or pathway for the purpose of pedestrian traffic abutting or running parallel or adjacent to a street.

Signage Signage is prohibited on all small cell facilities and wireless support structures, including stickers, logos, and other non-essential graphics and information unless required by the FCC and small placard identifying the service provider's contact information, which shall be placed facing away from the public rights of way.

Small Cell Facility(ies) means either:

- I. A wireless service facility that meets both of the following qualifications:
 - A. Each antenna is located inside an enclosure of no more than three cubic feet in volume or, in the case of an antenna that has exposed elements, the antenna and all of its exposed elements could fit within an imaginary enclosure of no more than three cubic feet; and
 - B. Primary equipment enclosures are no larger than seventeen cubic feet in volume. The following associated equipment may be located outside of the primary equipment enclosure and, if so located, is not included in the calculation of equipment volume: Electric meter, concealment, telecommunications demarcation box, ground-based enclosures, back-up power systems, grounding equipment, power transfer switch, and cut-off switch.
 - C. "Small Cell Facility" includes a Micro Wireless Facility.

Standards and Specifications means the latest edition of the City of Thornton Standards and Specifications for the Design and Construction of Public and Private Improvements.

Street, highway, or roadway means the entire width between the boundary lines of every ROW or easement publicly or privately maintained and open to the use of the public for the purposes of vehicular travel.

Structure means anything constructed or erected with a fixed location below, on, or above grade, including, without limitation, service cabinets, junction boxes, foundations, fences, retaining walls, awnings, balconies, and canopies.

Telecommunications means the transmission, between or among points specified by the user, of information of the user's choosing, without change in the form or content of the information as sent and received.

Telecommunication service(s) means the offering of telecommunications for a fee directly to the public, or to such classes of users as to be effectively available directly to the public, regardless of the facilities used.

Telecommunication service provider or *telecommunications applicant* means any provider of telecommunications services, except that such term does not include aggregators of telecommunications services (as defined in 47 U.S.C. Section 226).

Telecommunication system means the offering of telecommunications for a fee directly to the public, or to such classes of users as to be effectively available directly to the public, regardless of the facilities used. A system that provides both cable and telecommunications or information services may be considered both as a cable system and a telecommunications system pursuant to this Code.

Wireless facility(ies) means capital equipment and property, including but not limited to the optical fiber, wires, pipes, mains, conduits, ducts, pedestals, poles, antennas, cabinets and electronic equipment located in the streets used for transmitting, receiving, distributing, providing or offering wireless telecommunication services over the spectrum of radio frequencies licensed by the Federal Communications Commission.

Work means any and all types of construction activity or excavation performed within the City, in the ROW, and/or related to installation of public or private improvements in or on any property that is within the City limits or will be dedicated to the City as ROW.

2.2 Application Requirements

A ROW use agreement must be established between the city and the owner of the proposed small cell facilities prior to approval of any small cell permit applications. The process for obtaining a ROW use agreement is identified in City Code Section 2-271 – Occupation of ROW/application.

At a minimum a small cell permit application must include the documentation as listed in Section 2.2.2 of these Guidelines. Unless the wireless regulations provide otherwise, the applicant must submit an electronic copy (in a searchable format) of any application, as well as any amendments or supplements to the application or responses to requests for information regarding an application, to the Designated Staff. An application is not complete until electronic copies meeting the requirements of these guidelines are received by the Designated Staff.

An entity may submit a batched application of up to 10 individual small cell facilities at one time. If that entity submits more applications within one week of the previous batch, the City has the right to retain outside expertise to review those additional applications. All costs for the outside expertise shall be the responsibility of the submitting entity and must be paid before permits are issued.

2.2.1 Application Submittal and Review

The application review period begins to run when the application is received, and may be tolled if the approval authority determines that the application is incomplete and provides the applicant with notice as set forth below, or the application review period may also be tolled by mutual agreement of the city and applicant.

To toll the timeframe for review for incompleteness, the city will provide written notice to the applicant within thirty (30) days of the date of receipt of the application, clearly and specifically delineating all missing documents or information.

2.2.2 Application Requirements

- a. Cover sheet for the application listing all small cell facilities included in the submittal. (8.5" x 11" sheet size).
- b. Completed application form.
- c. A copy of the Right-of-Way Use Agreement (between the city and the owner of the small cell facilities) applicable to the small cell facilities included in the application.
- d. An area map for each proposed small cell facility showing the location of all existing above ground utility, streetlight, traffic signal, and free-standing wireless facility poles within 250 feet of the proposed facility. Identify what existing facility, if any that will be used or replaced for the proposed facility. Label existing poles using existing ID numbers if available.
- e. Detailed site and engineering plans for each proposed small cell facility, showing the location of work, work to be completed, limits of disturbance, etc. (11"x17" sheet size; drawings must be scaled)
- f. Detailed design drawings with dimensions of equipment for each proposed small cell facility, including manufacturer, model, and color. Design drawings may be included in the site and engineering plans. The design drawings must include all applicable poles, streetlights, antennas, cabinets, enclosures, etc.

- g. A letter, sealed and signed by a professional structural engineer licensed and registered by the State of Colorado, indicating the pole to which the small cell facility will be attached will safely support the intended loads.
- h. Certification by a certified RF engineer demonstrating compliance with the FCC standards for radio frequency emissions as they relate to the general public, including aggregate emissions for all co-located equipment.
- i. Copy of all required insurance certificates.
- j. A written description of any existing small cell facilities within the city owned by the owner of the small cell facilities proposed in the application and any anticipated future installations by the owner (if known), including latitudes and longitudes, for two years following the date of application submission. In lieu of written latitudes and longitudes, a Keyhole Markup Language Zipped (kmz) file may be submitted with the written description.
- k. Traffic control plans for each proposed small cell facility, showing all dimensions (in feet) of tapers, work zones, activity areas, diversions, detour routes, etc.
- l. Applicable stormwater management plan for each proposed small cell facility per city requirements (requirements may be determined during the city's review of the small cell facility plans).
- m. Adjacent property owner notification must occur for all residences, businesses, and properties within 250 feet of the small cell facility. A copy of the applicant's notification letter, a copy of the notification letter translated to Spanish, and certificates or proof of mailing must be provided. Small cell permits will not be issued until the letter and certificates or proof of mailing have been confirmed. The letter must be on letterhead of the owner of the small cell facility. The letter must notify residents, business owners, and property owners of the upcoming installation, type of installation (stand-alone, attachment, etc.), location, and include a sample depiction, photo, or drawing of the installation. A copy of the letter translated to Spanish must also be mailed to property owners. The owner or applicant's contact information and website must also be provided so residents, business owners, and property owners can obtain more information if desired. The letter shall not include any direction for residents, business owners, or property owners to contact the city regarding the applicant's small cell facilities. A copy of the letter shall be submitted to the city for review prior to mailing.

2.2.3 Application Approval Timeline and Shot Clock

The required approval timeline or "shot clock" for review of small cell facility applications is as follows:

- A sixty (60) day review period of an application for the collocation of small cell facilities.
- A ninety (90) day review period for the review of an application for construction of new stand-alone small cell facilities.

Existing shot clocks for non-small cell wireless facilities:

- Sixty (60) days for the review of an application for a collocation or modification which does not substantially change the existing structure and otherwise qualifies as an "eligible facilities request".
- Ninety (90) days for the review of an application for collocation which substantially changes the existing structure and does not qualify as an "eligible facilities request".
- One-hundred and fifty (150) days for the review of an application for deployment on a new structure.

Shot Clock Rules:

Both the new and existing shot clocks apply to “any approval that a siting authority must issue under applicable law prior to deployment.” This includes zoning approvals and building permits, and may also include license or franchise agreements to access the rights of way, leases for use of municipal poles or property in the rights of way, electric permits, and traffic control permits, among others.

For small cell facility deployments, shot clocks are reset if the siting authority notifies the applicant within 10 days after submission that the application is incomplete. For subsequent determinations of incompleteness, the shot clock would pause-not reset-if the siting authority provides written notice within 10 days that the supplemental submission did not provide the requested information.

For non-small cell facilities, shot clocks begin to run when an application is first submitted, and can be paused-not reset- if the siting authority notifies the applicant within 30 days that the application is incomplete. For subsequent determinations of incompleteness, the process is the same as described above for small cell facilities.

Failure to act within the new small cell facility shot clock constitutes a presumptive violation of the Communications Act and applications may seek expedited injunctive relief in court within 30 days of the local government missing a shot clock deadline. There is no “deemed granted” remedy.

2.2.4 Expiration of Approval

The FCC declaration is intended to assure the rapid deployment of small cell technology. In support of this goal, these Guidelines have established a 180-day period for the installation, inspection, and construction approval of a small cell facility. The City issued permit for small cell facilities in rights of way shall expire after 180 days from date of issuance of the permit unless the site has been fully installed, inspected, and the construction has been approved by the city. After 180 days, the applicant shall be required to resubmit a new application for the small cell facilities and sites under the expired permit.

2.2.5 Specific Exclusions

Fiber conduit and fiber cables/lines are not included in this process or approval and shall be reviewed by the City under a separate process. Maintenance and operation of small cell facilities is not included in this process, approval, or small cell permitting. Maintenance and operation activities impacting city ROW will require separate construction and traffic control permits.

2.3 Fees

The City’s fees are reasonable, objective, and are applied in a non-discriminatory manner. Therefore, the City will charge the following fees until further notice:

- A five-hundred dollar (\$500) non-recurring fee, which includes a single application that consists of up to five Small Cell Facilities, and an additional one hundred (\$100) fee for each small cell facility thereafter.
- A one thousand dollar (\$1,000) non-recurring fee for a new pole (not a collocation) intended to support one or more small cell facilities. The pole fee is not inclusive of the non-recurring fee for small cell siting.
- After paying all non-recurring siting and pole fees, Applicants will be charged two-hundred and seventy dollars (\$270) annually per small wireless facility. The recurring fee includes all possible ROW access fees or fees for attachment to municipally-owned structures in the ROW.

The above fees are not inclusive of any applicable fees for construction or traffic control permits.

All applicable fees shall be paid prior to final approval of any applicable small cell, construction, and traffic

control permits.

The City reserves the right to adjust fees it deems necessary to recover its reasonable costs for the small cell facility application and permitting process.

3. Pole Design Standards

3.1 Utility Distribution Poles

All attachments to utility distribution poles that provide aerial support for overhead utility lines without a streetlight attached shall be approved by Xcel Energy or United Power prior to installation. All equipment shall meet Xcel Energy or United Power requirements, Thornton's Right of Way requirements, these Guidelines, and all applicable Thornton permitting requirements.

- Antennas shall be located inside one RF transparent shroud a maximum of 9 cubic feet in size. The antenna shroud shall be mounted above the equipment shroud.
- The color of the RF transparent shroud shall be gray, unless otherwise approved or specified by the city.
- One equipment shroud containing all additional small cell equipment, backup power supply, etc. shall be installed. The maximum dimensions of the equipment shroud shall be 49" H x 19" W x 13" D. The equipment shroud shall be mounted a minimum of 7 feet above final grade.
- The color of the RF transparent shroud shall be gray, unless otherwise approved or specified by the city.
- A locked RF/power disconnect switch shall be attached to the pole.
- A meter housing meeting Utility requirements shall be installed on the pole. The meter housing shall be a maximum of 19" H x 13" W. The meter housing shall be oriented on the pole such that it does overhang any pedestrian, bicycle, or vehicle accessibility. The meter housing shall be mounted a minimum of 4 feet and maximum of 6 feet above final grade.
- A wiring and fiber optic cable shall be concealed within the pole or in conduit attached to the pole.
- Conduit attached to the pole shall be gray in color unless otherwise approved or specified by the city.
- Conduit shall be attached to the pole using two-hole conduit straps with fasteners every 2 feet on center.
- A pull box with tier 22 rated cover shall be located adjacent to the pole. Conduit attached to the pole shall transition underground and enter the bottom of the pull box via sweeps. Excluding sweeps and vertical rises, horizontal conduit runs shall be at a minimum depth of 2 feet from final grade to top of conduit.
- Exposed wiring and/or exposed fiber optic cable shall not be permitted unless otherwise approved by the City.
- The new pole shall have safety shutoff controls on the pole for the applicant to be able to turn off the small cell equipment upon request by the City for maintenance of nearby city-owned facilities and equipment

3.2 Streetlight Poles

No existing utility pole in the City whose sole purpose is for street lighting can be used to attach small cell facilities as such poles were not designed for small cell attachments. With the City and Utility approval (if applicable), the existing streetlight pole shall be replaced with a metal combined small cell and streetlight pole specifically designed to provide street lighting while also housing small cell equipment. Depending on the type of pole being replaced, an applicant may replace the existing streetlight pole with a metal combined

small cell and streetlight pole specifically designed to provide street lighting while also housing collocated equipment (up to two small cell facilities).

3.2.1 Xcel Energy and United Power Streetlight Poles

All metal combined small cell and streetlight poles and associated equipment shall meet Xcel Energy or United Power requirements and Thornton's Right of Way requirements, these Guidelines, and applicable Thornton permitting requirements. The city shall not be responsible for any cost associated with the pole or its installation. All pole designs shall be approved by both Xcel Energy or United Power and the city.

- The applicant shall place a new combined small cell and streetlight pole in place of the removed Xcel Energy or United Power streetlight pole or within 5 feet of the removed Xcel Energy or United Power streetlight pole.
- New poles shall match the style, shape, and color of existing poles and luminaires in the area, as determined by the City. The pole shall be designed and located in accordance with all applicable City requirements as specified in the City of Thornton Standards and Specifications, these Guidelines, Telecommunications Industry Association (TIA) 222 rev. G, and the American Association of State Highway and Transportation Officials (AASHTO) LRFD Specifications for Structural Supports for Highway Signs, Luminaires, and Traffic Signals, latest edition. Designs shall be similar to the designs shown in **Appendix A** or as otherwise approved by the City.
- The maximum outside diameter of the pole shall be 12 inches. The maximum outside diameter of post-top mounted residential poles shall be 10 inches.
- Foundations shall be designed to meet the structural requirements of the pole and in compliance with American Concrete Institute (ACI) 318 standard. A foundation detail or drawing stamped by a professional structural engineer licensed and registered by the State of Colorado shall be submitted to the City. Precast foundations are preferred and should be installed whenever possible.
- A minimum of two spare conduit sweeps shall be provided in the foundation for future service.
- The length of the luminaire arm of the new pole shall match the length of the luminaire arm of the preexisting pole unless otherwise approved by the City. The luminaire arm and luminaire attached to the new pole shall match the style of the luminaire arm and luminaire attached to the preexisting pole, unless otherwise approved by the City. For Xcel Energy poles, the luminaire shall not be converted to LED and the method of lighting shall be the same as the preexisting pole. For United Power poles, the luminaire shall be converted to LED meeting United Power specifications if the preexisting luminaire is not already LED.
- The new pole shall be capable of supporting a top and bottom arm-mounted vinyl banner three feet (3') by six feet (6') in size. In addition to banners, fifteen (15) percent of the structural capacity of the pole shall be reserved for the possible installation of future City Internet of Things equipment.
- The applicant shall wire the small cell equipment to its own meter (if applicable) and power source, with recurring monthly electric service and metering paid for by the applicant.
- The applicant shall wire the streetlight luminaire to a power source as designated by Xcel Energy or United Power, with recurring monthly electric service charged at the required Xcel Energy or United Power rate and paid for by the City.
- The new pole shall have a round equipment cabinet integrated at the base of the pole. The cabinet shall be a maximum of 20 inches in diameter and have a maximum height of 6 feet. The cabinet for post-top mounted residential poles shall have a maximum diameter of 14 inches.
- If the new pole is capable of housing two small cell facilities, the equipment for the second small cell facility, excluding antenna and meter, shall be housed in an equipment enclosure within the

pole section. If the equipment enclosure within the pole is used by a second applicant, the second applicant is still required to obtain a right-of-way use agreement, small cell permit, and is subject to these guidelines.

- A tapered transition between the lower pole and the cabinet shall be provided. The color of the tapered transition shall match the color of the pole.
- Antennas shall be located inside a round “cantenna” style shroud of no more than 16 inches in diameter. The height of the cantenna from top of the riser pole and attachment point to top of the cantenna shall be a maximum of 7 feet 6 inches.
- Panel or prismatic antennas that cannot be shrouded due to functionality shall be oriented such that the maximum diameter encompassing the outer edge points of all panel or prismatic antennas is a maximum of 20 inches. The height of the panel or prismatic antenna from top of riser pole and attachment point to top of the panel or prismatic antenna shall be a maximum of 7 feet 6 inches.
- A tapered transition between the upper pole and the cantenna or panel antenna or prismatic antenna shall be provided. The color of the tapered transition shall match the color of the pole.
- The antenna for poles with post-top mounted streetlights shall be housed within RF transparent sections of the pole below the streetlight.
- The color of the antenna or shroud shall match the color of the pole.
- All wiring shall be concealed inside the pole within a channel separate from Utility wiring within the pole.
- If the new pole is placed within 5 feet of the removed streetlight pole, any existing caisson of the removed streetlight pole shall be demolished to a minimum of 18 inches below ground surface. Landscaping shall be restored above the removed caisson to the satisfaction of the City.
- A pull box with tier 22 rated cover shall be located adjacent to the pole. Excluding sweeps and vertical rises, horizontal conduit runs shall be at a minimum depth of 2 feet from final grade to top of conduit.
- All equipment, wiring, and cables, excluding the antenna and meter, must be concealed within the pole or placed in a flush-to-grade underground equipment vault with tier 22 rated cover unless otherwise demonstrated to not be feasible.
- The new pole shall have safety shutoff controls on the pole for the applicant to be able to turn off the small cell equipment upon request by the City for maintenance of nearby city-owned facilities and equipment

3.2.2 City-Owned Streetlight Poles

No small cell facility shall be attached to any existing City-owned streetlight pole unless the existing streetlight pole was specifically designed to support small cell equipment. In all other cases, the applicant shall have the existing City-owned streetlight pole removed and a new metal combined small cell and streetlight pole shall be installed. The new combined small cell and streetlight pole shall be dedicated to City ownership. The applicant shall be responsible for any and all costs for removal of the preexisting City-owned streetlight pole and installation of the new combined small cell and streetlight pole. All combined small cell and streetlight poles and associated equipment shall meet Thornton’s Right of Way requirements, these Guidelines, and applicable Thornton permitting requirements.

- The applicant shall place a new combined small cell and streetlight pole in place of the removed

City-owned streetlight pole or within 5 feet of the removed City-owned streetlight pole.

- New poles shall match the style shape and color of existing poles and luminaires in the area. The pole shall be designed and located in accordance with all City requirements as specified in the City of Thornton Standards and Specifications, these Guidelines, and the American Association of State Highway and Transportation Officials (AASHTO) LRFD Specifications for Structural Supports for Highway Signs, Luminaires, and Traffic Signals, latest edition. All pole designs shall be approved by the City prior to submission of an application for small cell approval. Designs shall be in accordance with the designs shown in **Appendix A** or as otherwise approved by the City.
- The maximum outside diameter of the pole shall be 12 inches. The maximum outside diameter of post-top mounted residential poles shall be 10 inches.
- Foundations shall be designed to meet the structural requirements of the pole and in compliance with American Concrete Institute (ACI) 318 standard. A foundation detail or drawing stamped by a professional structural engineer licensed and registered by the State of Colorado shall be submitted to the City. Precast foundations are preferred and should be installed whenever possible.
- A minimum of two spare conduit sweeps shall be provided in the foundation for future service.
- The length of the luminaire arm of the new pole shall match the length of the luminaire arm of the preexisting pole unless otherwise approved by the City. The luminaire arm and luminaire attached to the new pole shall match the style of the luminaire arm and luminaire attached to the preexisting pole, unless otherwise approved by the City. The luminaire shall be LED meeting City requirements.
- The new pole shall be capable of supporting a top and bottom arm-mounted vinyl banner three feet (3') by six feet (6') in size. In addition to banners, fifteen (15) percent of the structural capacity of the pole shall be reserved for the possible installation of future City Internet of Things equipment.
- The applicant shall wire the small cell equipment to its own meter (if applicable) and power source, with recurring monthly electric service and metering paid for by the applicant.
- The applicant shall wire the LED streetlight luminaire to the previously existing power source, with recurring monthly electric service and metering (if applicable) continuing to be paid for by the City.
- The new pole shall have a round equipment cabinet integrated at the base of the pole. The cabinet shall be a maximum of 20 inches in diameter and have a maximum height of 6 feet. The cabinet for post-top mounted residential poles shall have a maximum diameter of 14 inches.
- If the new pole is capable of housing two small cell facilities, the equipment for the second small cell facility, excluding antenna and meter, shall be housed in an equipment enclosure within the pole section. If the equipment enclosure within the pole is used by a second applicant, the second applicant is still required to obtain a right-of-way use agreement, small cell permit, and is subject to these guidelines.
- A tapered transition between the lower pole and the cabinet shall be provided. The color of the tapered transition shall match the color of the pole.
- Antennas shall be located inside a round "cantenna" style shroud of no more than 16 inches in diameter. The height of the cantenna from top of the riser pole and attachment point to top of the cantenna shall be a maximum of 7 feet 6 inches.
- Panel or prismatic antennas that cannot be shrouded due to functionality shall be oriented such that the maximum diameter encompassing the outer edge points of all panel or prismatic antennas is a maximum of 20 inches. The height of the panel or prismatic antenna from top of riser pole and attachment point to top of the panel or prismatic antenna shall be a maximum of 7 feet 6 inches.

- A tapered transition between the upper pole and the antenna or panel antenna or prismatic antenna shall be provided. The color of the tapered transition shall match the color of the pole.
- The antenna for poles with post-top mounted streetlights shall be housed within RF transparent sections of the pole below the streetlight.
- The color of the antenna or shroud shall match the color of the pole.
- All wiring shall be concealed inside the pole within a channel separate from municipal wiring within the pole.
- If the new pole is placed within 5 feet of the removed streetlight pole, any existing caisson of the removed streetlight pole shall be demolished to a minimum of 18 inches below ground surface. Landscaping shall be restored above the removed caisson to the satisfaction of the City.
- A pull box with tier 22 rated cover shall be located adjacent to the pole. Excluding sweeps and vertical rises, horizontal conduit runs shall be at a minimum depth of 2 feet from final grade to top of conduit.
- All equipment, wiring, and cables, excluding the antenna and meter, must be concealed within the pole or placed in a flush-to-grade underground equipment vault with tier 22 rated cover unless otherwise demonstrated to not be feasible.
- The new pole shall have safety shutoff controls on the pole for the applicant to be able to turn off the small cell equipment upon request by the City for streetlight and pole maintenance purposes.
- The City shall be the owner of the new pole and luminaire upon completion of construction. The applicant shall retain ownership of any small cell equipment.
- Removed City-owned streetlights and luminaires shall be salvaged and returned to the City of Thornton Infrastructure Maintenance Center at no cost to the City.

3.3 Municipal Traffic Signal Poles

Applicants may submit applications to install small cell facilities on municipally-owned traffic signal poles. The City will consider such applications assuming the pole is not expected to be used for emergency communications or tolling equipment. No small cell facility shall be attached to any existing traffic signal pole unless the existing traffic signal pole was specifically designed to support small cell equipment. In such cases, the applicant shall replace the traffic signal pole and mast arm with a traffic signal pole and mast arm designed to accommodate the small cell equipment in addition to the required traffic signal and streetlight equipment. An applicant may be limited to one municipally-owned traffic signal pole within 300 feet. For example, at a signalized intersection there are generally 4 signal poles. A single applicant may be approved for only 1 of the 4 signal poles. Other applicants may be approved for the other poles.

- New traffic signal poles, mast arms, luminaire arms, and luminaires shall match the style, shape, and color of existing traffic signal poles at the intersection. The pole shall be designed and located in accordance with all City requirements as specified in the City of Thornton Standards and Specifications (for capital improvement projects), these Guidelines, and the American Association of State Highway and Transportation Officials (AASHTO) LRFD Specifications for Structural Supports for Highway Signs, Luminaires, and Traffic Signals, latest edition. All pole designs shall approved by the City.
- Foundations shall be designed to meet the structural requirements of the pole and in conformance with the City of Thornton Standards and Specifications (for capital improvement projects). A foundation detail or drawing stamped by a professional structural engineer licensed and registered

by the State of Colorado shall be submitted to the City.

- Two 3-inch conduits and one 2-inch conduit shall be provided from the City's traffic signal pull box into the base of the traffic signal pole. A minimum of two spare conduit sweeps shall be provided in the foundation for future service. Excluding sweeps and vertical rises, horizontal conduit runs shall be at a minimum depth of 2 feet from final grade to top of conduit.
- The applicant shall provide its own pull box for access to conduits in the base of the traffic signal pole. The City's pull boxes shall not be used for small cell purposes.
- The length of the luminaire arm of the new pole shall match the length of the luminaire arm of the preexisting pole unless otherwise approved by the City. The length of the mast arm of the new pole will be determined by the placement of the new pole and shall be approved by the City.
- If the preexisting luminaire is owned by Xcel Energy, the luminaire shall not be converted to LED and the method of lighting shall be the same as the preexisting luminaire. If the preexisting luminaire is owned by the City, the new luminaire shall be LED meeting City requirements.
- Fifteen (15) percent of the structural capacity of the pole shall be reserved for the possible installation of future City equipment.
- The applicants shall provide its own meter, power, and fiber (or other communications medium) to their small cell facility attached to the traffic signal pole, with recurring monthly electric service for the applicant's small cell equipment paid for by the applicant. Recurring monthly electric service for the traffic signal and luminaire shall continue to be paid for by the City.
- Per Xcel Energy requirements, any modification to the traffic signal that results in a change in electrical load for the traffic signal will require the installation of a meter (if the traffic signal is not already metered). The applicant shall install such meter in conformance with Xcel Energy and City requirements and the applicant shall be responsible for all installation costs. After installation, the city shall be responsible for the recurring monthly electric service for the traffic signal and luminaires.
- All equipment, wiring, and cables, excluding the antenna and meter, must be concealed within the pole or placed in a flush-to-grade underground equipment vault with tier 22 rated cover unless otherwise demonstrated to not be feasible.
- All wiring shall be concealed inside the signal pole within a channel separate from municipal wiring within the pole.
- Small cell equipment shall not be attached to any mast arms or luminaire arms.
- Antennas shall be located inside a round "cantenna" style shroud of no more than 16 inches in diameter. The height of the cantenna from top of the riser pole and attachment point to top of the cantenna shall be a maximum of 7 feet 6 inches. However, the maximum height of the combined traffic signal pole, luminaire extension, and antenna shall not exceed 40 feet from established grade to top of cantenna.
- Panel or prismatic antennas that cannot be shrouded due to functionality shall be oriented such that the maximum diameter encompassing the outer edge points of all panel or prismatic antennas is a maximum of 20 inches. The height of the panel or prismatic antenna from top of riser pole and attachment point to top of the panel or prismatic antenna shall be a maximum of 7 feet 6 inches. However, the maximum height of the combined traffic signal pole, luminaire extension, and antenna shall not exceed 40 feet from established grade to top of antenna.
- A tapered transition between the upper pole and the cantenna or panel antenna or prismatic antenna shall be provided. The color of the tapered transition shall match the color of the pole.

- The color of the antenna or shroud shall match the color of the pole.
- In cases of wood signal poles, the applicant(s) shall replace the wood pole with an acceptable metal signal pole meeting all City requirements as specified in the City of Thornton Standards and Specifications and these guidelines.
- If the new pole is placed adjacent to the removed pole, any existing caisson of the removed pole shall be demolished to a minimum of 18 inches below ground surface. The landscaping or sidewalk shall be restored above the removed caisson to the satisfaction of the City.
- The new pole shall have safety shutoff controls on the pole for the applicant to be able to turn off the small cell equipment upon request by the City for traffic signal, streetlight, and pole maintenance purposes.
- The applicant must demonstrate that the small cell installation will not interfere with the operation of the traffic signal or traffic signal communication systems.
- The City shall be the owner of the new traffic signal pole, mast arm, traffic signal equipment, luminaire arm, and luminaire upon completion of construction. The applicant shall retain ownership of any small cell equipment.
- Removed traffic signal poles, mast arms, luminaire arms, luminaires, and equipment shall be salvaged and returned to the City of Thornton Infrastructure Maintenance Center at no cost to the City.
- If the traffic signal is jointly owned by the City and another municipality or municipalities, the small cell facilities shall be in compliance with all permitting, design, and code requirements for all municipalities that jointly own the traffic signal.
- If the traffic signal is owned by the Colorado Department of Transportation (CDOT), the small cell facility shall be in compliance with CDOT small cell permitting, design, and code requirements.

3.4 Applicant-Owned Poles

Applicants may submit applications to install small cell facilities on new applicant-owned poles.

- New applicant-owned poles shall match the style shape and color of existing poles in the area, as determined by the City. The pole shall be designed and located in accordance with all applicable City requirements as specified in the City of Thornton Standards and Specifications, these Guidelines, Telecommunications Industry Association (TIA) 222 rev. G, and the American Association of State Highway and Transportation Officials (AASHTO) LRFD Specifications for Structural Supports for Highway Signs, Luminaires, and Traffic Signals, latest edition. . Design of the applicant-owned pole shall be similar to the designs shown in **Appendix A** or as otherwise approved by the City. All pole designs shall be approved by the City.
- The maximum outside diameter of the pole shall be 12 inches.
- Foundations shall be designed to meet the structural requirements of the pole and in compliance with American Concrete Institute (ACI) 318 standard. A foundation detail or drawing stamped by a professional structural engineer licensed and registered in the State of Colorado shall be submitted to the City. Precast foundations are preferred and should be installed whenever possible.
- A minimum of two spare conduit sweeps shall be provided in the foundation for future service.
- The applicant shall wire the small cell equipment to its own meter, with recurring monthly electric service and metering paid for by the applicant.

- The new pole shall have a round equipment cabinet integrated at the base of the pole. The cabinet shall be a maximum of 20 inches in diameter and have a maximum height of 6 feet.
- If the new pole is capable of housing multiple small cell facilities, the equipment for the additional small cell facilities, excluding antenna and meter, shall be housed in equipment enclosures within the pole section. If the additional equipment enclosures within the pole are used by other applicants, the other applicants are still required to obtain a right-of-way use agreement, small cell permit, and are subject to these guidelines.
- Antennas shall be located inside a round “cantenna” style shroud of no more than 16 inches in diameter. The height of the cantenna from top of riser pole and attachment point to top of the cantenna shall be a maximum of 7 feet 6 inches.
- Panel or prismatic antennas that cannot be shrouded due to functionality shall be oriented such that the maximum diameter encompassing the outer edge points of all panel or prismatic antennas is a maximum of 20 inches. The height of the panel or prismatic antenna from top of riser pole and attachment point to top of the panel or prismatic antenna shall be a maximum of 7 feet 6 inches.
- A tapered transition between the upper pole and the cantenna or panel antenna or prismatic antenna shall be provided. The color of the tapered transition shall match the color of the pole.
- The color of the antenna or shroud shall match the color of the pole.
- All wiring shall be concealed inside pole.
- A pull box with tier 22 rated cover shall be located adjacent to the pole. Excluding sweeps and vertical rises, horizontal conduit runs shall be at a minimum depth of 2 feet from final grade to top of conduit.
- All equipment, wiring, and cables, excluding the antenna and meter, must be concealed within the pole or placed in a flush-to-grade underground equipment vault with tier 22 rated cover unless otherwise demonstrated to not be feasible.
- The new pole shall have safety shutoff controls on the pole for the applicant to be able to turn off the small cell equipment upon request by the City for maintenance of nearby city-owned facilities and equipment.

4. Pole Location, Height, and Sign Standards

4.1 Location

The City reserves the right to approve all proposed pole locations and to modify those locations as necessary for future City needs, functional, and/or aesthetic reasons. Relocations of small cell equipment requested by the City shall be at sole cost and expense of the owner of the small cell equipment. The City will work with the applicant to find a suitable location for both the City and the applicant.

4.1.1 Permitted Locations

Poles and equipment shall be located as follows:

- Small cell facilities shall not be located on historically or architecturally significant structures unless visually and architecturally integrated with the structure and shall not interfere with prominent vistas or significant public view corridors.
- New applicant-owned small cell poles shall be located no closer than 250 feet radially to other applicant-owned poles, regardless of ownership. New applicant-owned small cell poles shall be located no closer than 25 feet radially to any other poles.
- Poles shall be located on property lines wherever possible. Where possible, the poles shall be sited to take advantage of existing screening.
- All equipment and poles located within the ROW shall be located such that it meets the requirements of the Americans with Disabilities Act (ADA) and does not obstruct, impede, or hinder usual pedestrian, bicycle, or vehicular travel. Any pole and/or associated small cell equipment shall not obstruct any sight distance as defined in City Code, any traffic control signs, signals, or devices, access to any public transportation facilities or bus stops, or access to any ingress or egress points to any public or private facilities in or adjacent to the public right of way.

4.1.2 Excluded Locations

Exclusions to pole and equipment locations are as follows:

- Within 30 feet of a fire hydrant unless replacing an existing pole in the same location, reduced distances can be approved by the City.
- In any manner which would obstruct a public sidewalk, trail, or roadway including reducing vertical clearances required by the City.
- Closer than 2 feet from curb or sidewalk.
- Within 10 feet of a driveway.
- Within 15 feet of a tree trunk, measured from the exterior of the trunk, to protect the health of the tree.
- Within roadway medians due to non-breakaway design.
- No equipment, shelters, or cabinets, and no electrical distribution panels may be at ground level, except after all reasonable alternative pole locations have been explored and found unavailable or lacking in some substantial way, and only with the prior written approval of the City upon a good faith showing of necessity, and upon such conditions as the City deems appropriate under the circumstances. The City shall weigh such requests against historic preservation policies, aesthetic considerations, pedestrian, and disabled person access to

sidewalks, public safety concerns, technical installation conflicts, and compliance with all applicable laws.

4.1.3 Historical Districts, Parks, and Open Space

Section 19-3 of City Code defines a historical district as meaning “a geographically definable area that has been designated as such by the City because of its historic significance and importance to the community. A historical district includes a concentration, linkage or continuity of sites, buildings, structures, and/or physical features. A district is related by a pattern of either physical elements or social activities. A term “district” may include neighborhood, agricultural or commercial districts”. Section 19-3 of City Code defines a landmark as meaning “a property or structure designated by resolution of the City Council, that is worthy of rehabilitation, restoration and preservation because of its cultural, architectural and/or historical significance to the city”. In areas of the City identified as parks and open space or designated as a historical district, or within 500 feet of a landmark, the applicant shall conduct a consultation with the applicable departments, divisions, or personnel of the City to discuss aesthetically significant structures, views, or community features and options to minimize any adverse aesthetic impacts of attaching or installing small cell facilities in such areas.

4.2 Height

Height requirements shall be as follows:

- The height of the pole shall be based on the existing streetlights in public right-of-way adjacent to where it is to be placed.
- For a small cell facility located adjacent to post-top streetlights, the overall height of the wireless support structure and any antennas shall not be more than 30 feet in height above established grade measured at the base of the wireless support structure.
- For a small cell facility located adjacent to arm mounted cobra head streetlights or adjacent to shepherds hook streetlights, the overall height of the wireless support structure and any antennas shall not exceed 40 feet in height above established grade measured at the base of the wireless support structure.
- For a small cell facility attached to a traffic signal pole, the overall height of the traffic signal pole and small cell antenna shall not exceed 40 feet in height above established grade measured at the base of the traffic signal.
- Antennas must be located at a minimum of 20 feet above established grade measured at the base of the wireless support structure.

4.3 Signs

Signage is prohibited on all small cell facilities and wireless support structures, including stickers, logos, and other non-essential graphics and information with the following exceptions:

- Required by the FCC.
- A required small placard identifying the service provider and providing a 24-hour contact number, which shall be placed facing away from the public rights of way.
- RF caution signs.

5. Safety Requirements and Noise

Prevention of failures and accidents. Any Person who owns a Small Cell Facility and/or Wireless Support Structure sited in the ROW shall at all times employ ordinary and reasonable care and install and maintain in use industry standard technology for preventing failures and accidents which are likely to cause damage, injury, or nuisance to the public.

Compliance with fire safety and FCC regulations. Small cell facilities, wires, cables, fixtures, and other equipment shall be installed and maintained in compliance with the requirements of the National Electric Code, and all FCC, state, and local regulations.

Changes in state or federal standards and regulations. If state or federal standards and regulations are amended such that existing small cell facilities and/or Wireless Support Structures must be brought into compliance with the amended standards and regulations, the owners of the small cell facilities and/or Wireless Support Structures governed by these Guidelines shall bring any non-conforming facilities and/or structures into compliance with the revised standards and regulations within six months of the effective date of the standards and regulations, unless a different compliance schedule is mandated by the regulating agency or the facility is otherwise permitted to continue as existing. Failure to bring small cell facilities and/or Wireless Support Structures into compliance with any revised standards and regulations shall constitute grounds for removal at the owner's expense.

Noise. The applicant is required to incorporate ambient noise suppression measures and/or required to place the equipment in locations less likely to impact adjacent residences or businesses to ensure compliance with all applicable noise regulations. The maximum allowable noise emitted by the small cell facility shall not exceed 50 dBA measured at a distance of 3 feet from any portion of the facility.

Appendix A: Designs

The following diagrams and information were provided by, and used with the permission of, Comptek Technologies/CityPole®. The inclusion of this information in no way indicates that the City endorses CityPole or its products.

A.1 Diagram of Small Cell Facility Pole

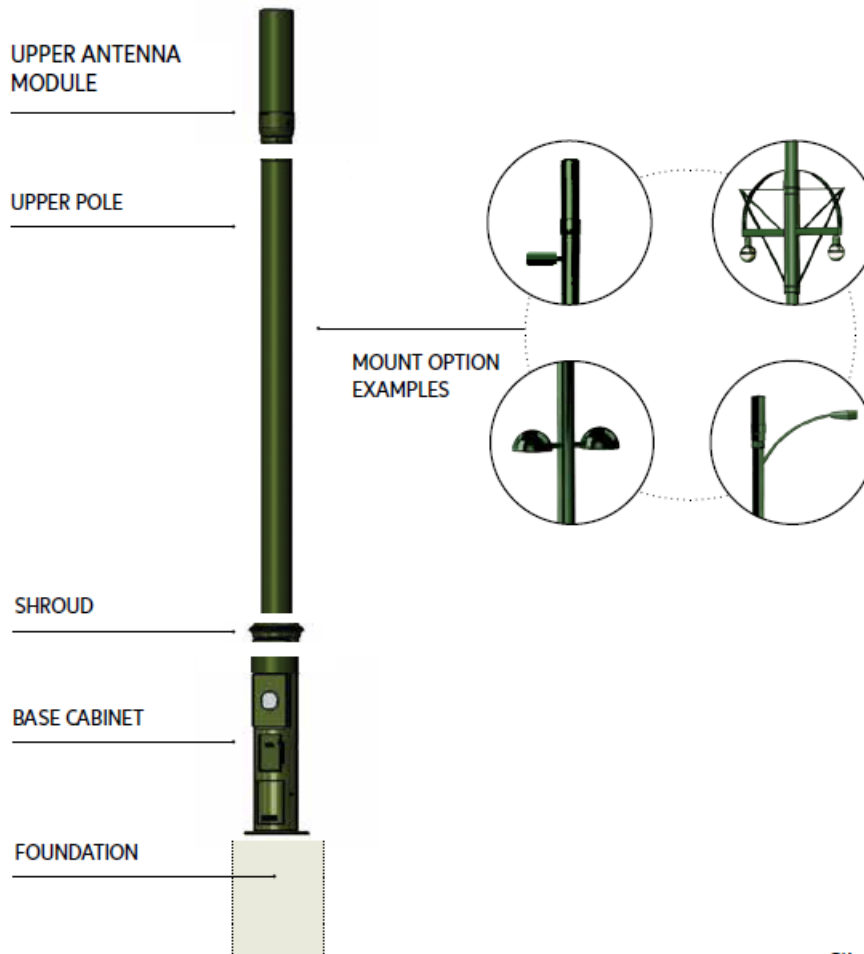

CityPole.com

The following diagrams and information were provided by, and used with the permission of, Comptek Technologies/CityPole® and Valmont Structures®. The inclusion of this information in no way indicates that the City endorses CityPole or its products or Valmont Structures® or its products.

A.2 Base Cabinet

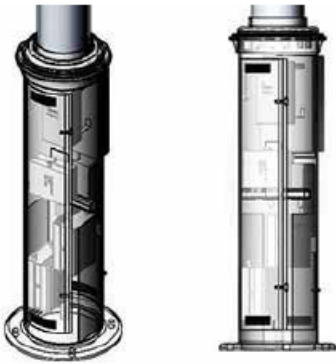

Integrated wireless equipment in base cabinet.



The base cabinet can be configured with a wide range of electrical disconnects to meet local building codes and preferences.

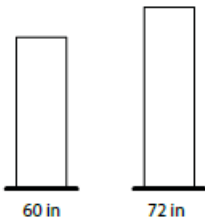

The base cabinet height can be chosen to house future equipment and complement local cityscapes.



Round Structural Base Cabinet

The following diagrams and information were provided by, and used with the permission of, Comptek Technologies/CityPole® and Valmont Structures®. The inclusion of this information in no way indicates that the City endorses CityPole or its products or Valmont Structures® or its products.

A.3 Upper Antenna Module

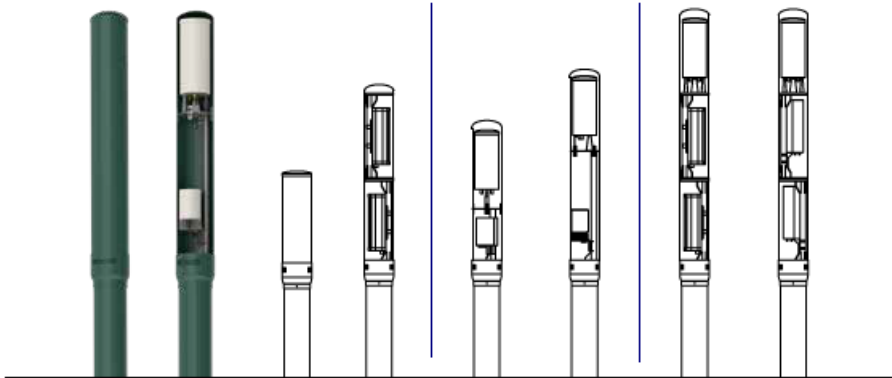

The upper antenna module can be easily reconfigured for a number of technology generations. These includes multiple configurations of cellular technology, various backhaul and low power options such as WiFi, Bluetooth, or Zigbee, and as many as three different technology generations.

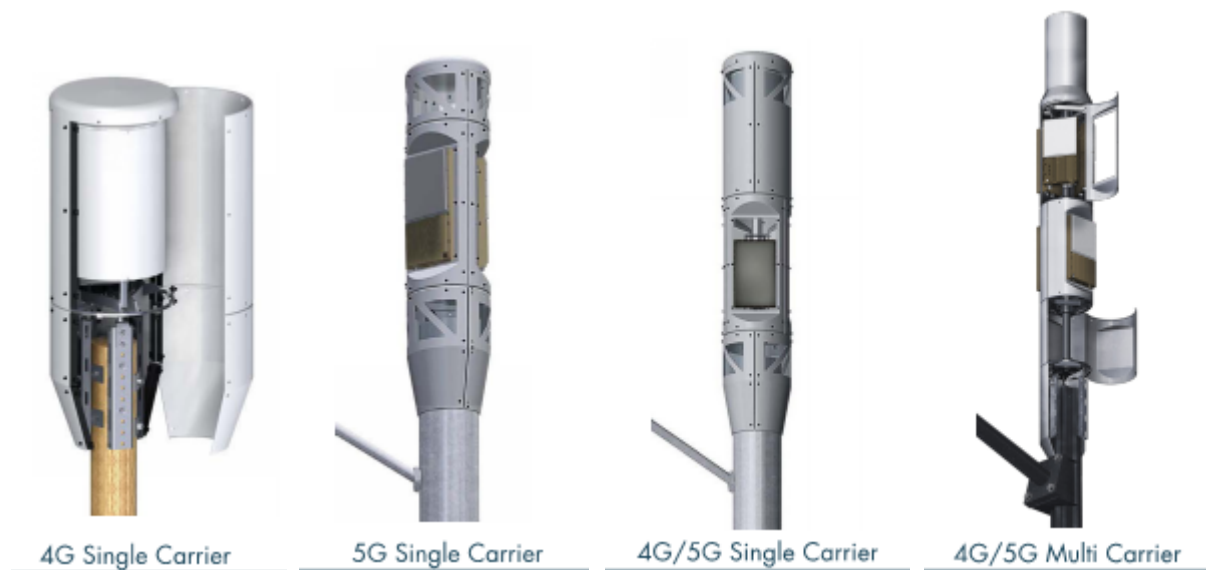

The following diagrams and information were provided by, and used with the permission of, Comptek Technologies/CityPole® and Valmont Structures®. The inclusion of this information in no way indicates that the City endorses CityPole or its products or Valmont Structures® or its products.

A.4 Foundation Selection



CityPole® pre-cast foundation speeds work in the Right of Way.



Caisson and custom designs are available.

The following diagrams and information were provided by, and used with the permission of, Comptek Technologies/CityPole®. The inclusion of this information in no way indicates that the City endorses CityPole or its products.

A.5 Lighting Accessories

